

MSI All-In-One Touchscreen Quick Setup Guide



AWE Learning All-In-One Components

- AWE Learning All-In-One System
- AWE Learning Kid-Friendly Keyboard & Mouse
- AWE Learning Mouse Pad
- Power Cables

Support: 866.463.6357 | Sales: 888.293.0272 | info@awelearning.com

www.awelearning.com

10.30.2025

Parts Identification



Welcome Pack



AWE Learning Keyboard & Mouse

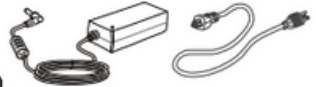

AC/DC Adapter & AC Power Cord



Mouse Pad

Connections for Power, Keyboard, Mouse, Headphones, and Network

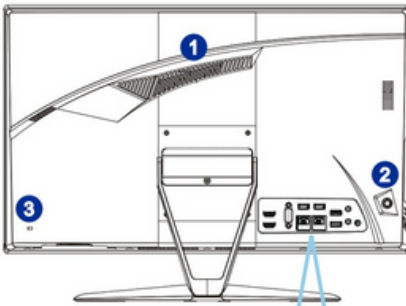

Workstation Back View

1. Base / Stand
2. Power Jack
3. Kensington Lock Port
4. RJ-45 LAN Jack
5. HDMI-Out Port
6. USB 3.1 Gen 1 Port (Type-A)
7. USB 2.0 Port (Type-A)

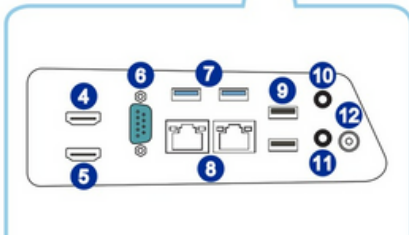

Workstation Side Views

1. Hard Drive Disk LED
2. USB 3.1 Gen1 Port
3. Line-Out Jack
4. System Power Button / LED

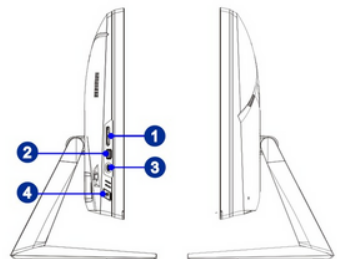

Setup

Position Your System

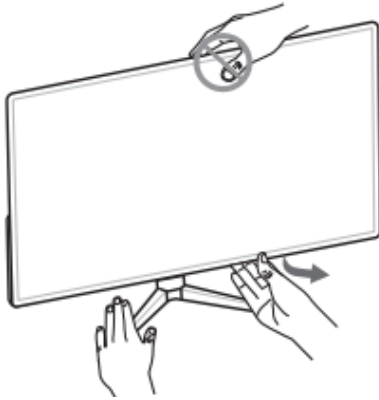

- Do not use any sharp objects on the display panel.
- Avoid pressing the display panel when adjusting.

Connecting the Power and Turning On

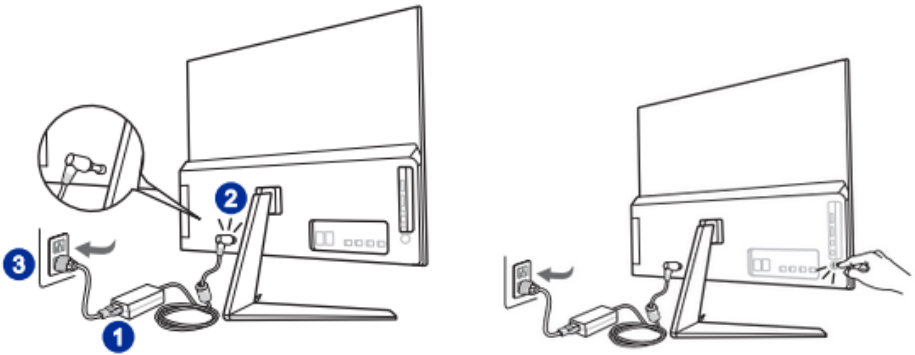

Getting Started

When you setup your AWE Learning workstation for the first time, we recommend that you set the following functions within the Administrative Control Panel:

1. Administrative Control Panel Password

To access the Administrative Control Panel, click on the gear icon in the top right corner of the desktop interface. This will display information about your workstation. Click on the Open Administrator Panel button. The first time this loads, you will be asked to create an Administrator Password. This password will be required every time you access the Administrative Control Panel, so please keep your password details safe.

2. Set the Date & Time

For synchronization and accurate usage statistics, it is essential that the workstation time and date are correct. To set the date & time, click on the Administration tab, and click the button labeled Edit Time/Date. Set the current time and date.

3. Shut Down Your Unit

To power down your unit, click on the door icon in the top right navigation. This will end your session. Click on the power button on the bottom right corner. In order to avoid users turning off the unit, you will be prompted to enter your Admin Panel password to successfully power down the workstation.

4. Access the Customer Portal

The Customer Portal is a great resource for you to access detailed utilization statistics for your workstation. All statistics are automatically uploaded on networked AWE Learning workstations, or can be manually uploaded via USB. This allows you to access detailed reporting, utilization statistics, view account information, check warranty status, and much more.

Access the Customer Portal from any internet-enabled device: <https://portal.awe-net.com>

5. AWE Learning Admin Guide

For further information about your AWE Learning workstation, please read the Admin Guide that is accessible from our online Welcome Kit:

<https://awelearning.com/welcome-kit>.

Notes

- Do not hang or place any objects (such as headphones, signage) on the touchscreen. This will affect functionality. If an object is touching the screen, remove it and reboot.
- For the integrity and functionality of your AWE Learning workstation, we strongly recommend using a surge protector.
- We recommend that you run cables underneath the computer and safely secure them.
- This workstation comes with an industry leading three-year limited warranty and access to our excellent U.S.-based Customer Support team. Please review your purchase contract for further warranty information.
- Keep Original Packaging as units are required to be returned in original packaging if repairs are needed in the future. AWE will not provide packaging for any return shipments at no cost.

Support

For any inquiries, please review our list of Frequently Asked Questions (FAQs) on our website at www.awelearning.com/support

Our Customer Support team is available Monday-Friday, 9am-5pm EST, and can be reached by phone at 1-866-463-6357 or by email at support@awelearning.com



Support: 866.463.6357 | Sales: 888.293.0272 | info@awelearning.com

www.awelearning.com

© 2025 AWE Acquisition, Inc. All rights reserved.